

NOTES-- PLEASE READ!!!!

- CLEARANCE CHECK MUST BE PERFORMED WITH SHOCK AT FULL EXTENSION, FULL COMPRESSION AND ALL POINTS IN BETWEEN. (INSTALL SHOCK WITHOUT SPRING TO ALLOW SUSPENSION TO COMPRESS EASILY FOR CLEARANCE CHECKS)
- PAY SPECIAL ATTENTION TO CLEARANCE AROUND RESERVOIR AND ADJUSTER KNOBS AT FULL TRAVEL.
- ENSURE CLEARANCE FOR FRAME FLEX.
- ENSURE CLEARANCE FOR MUD BUILDUP.
- CUSTOMER IS RESPONSIBLE FOR BROKEN SHOCKS DUE TO LACK OF CLEARANCE.

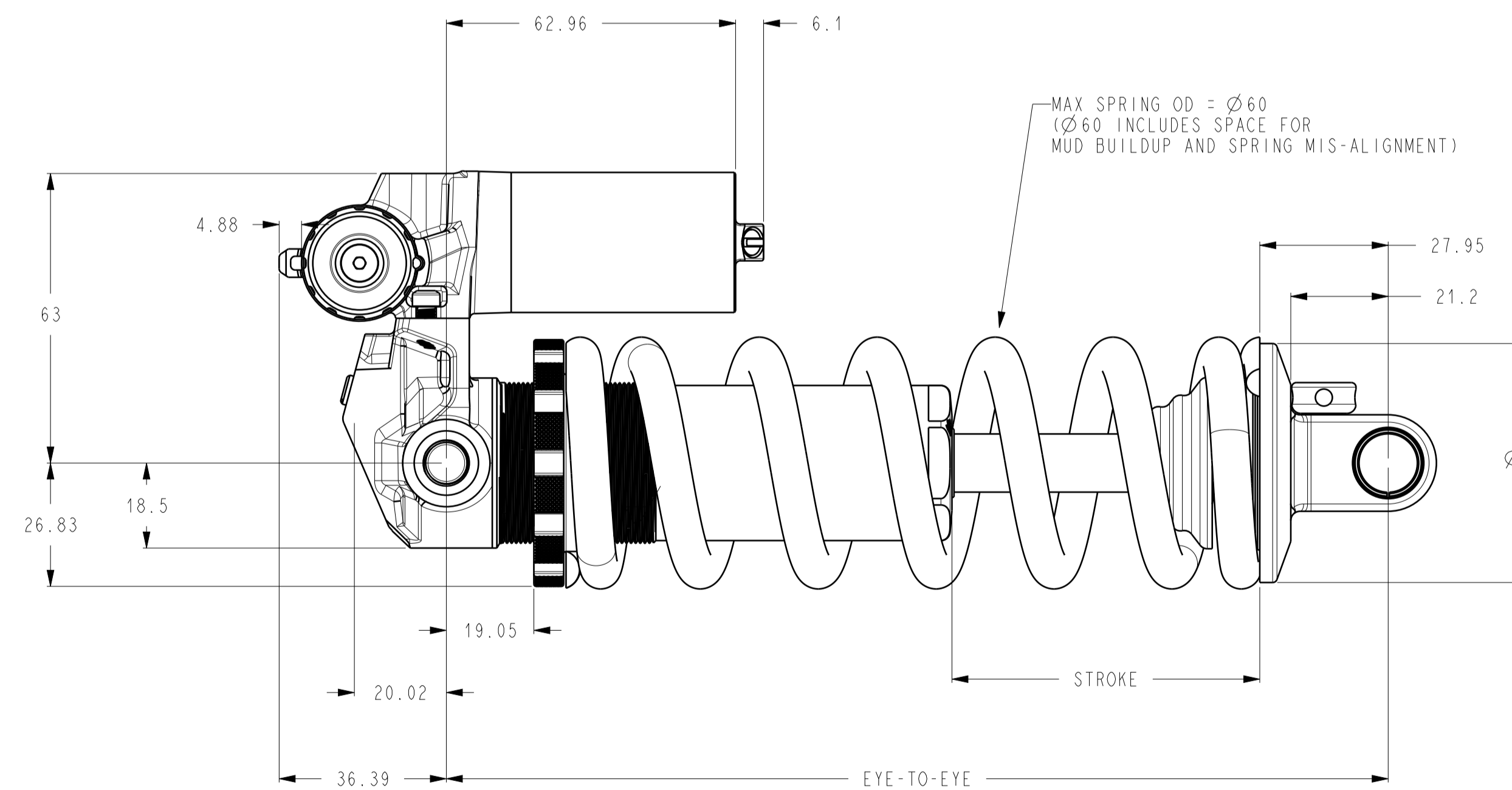
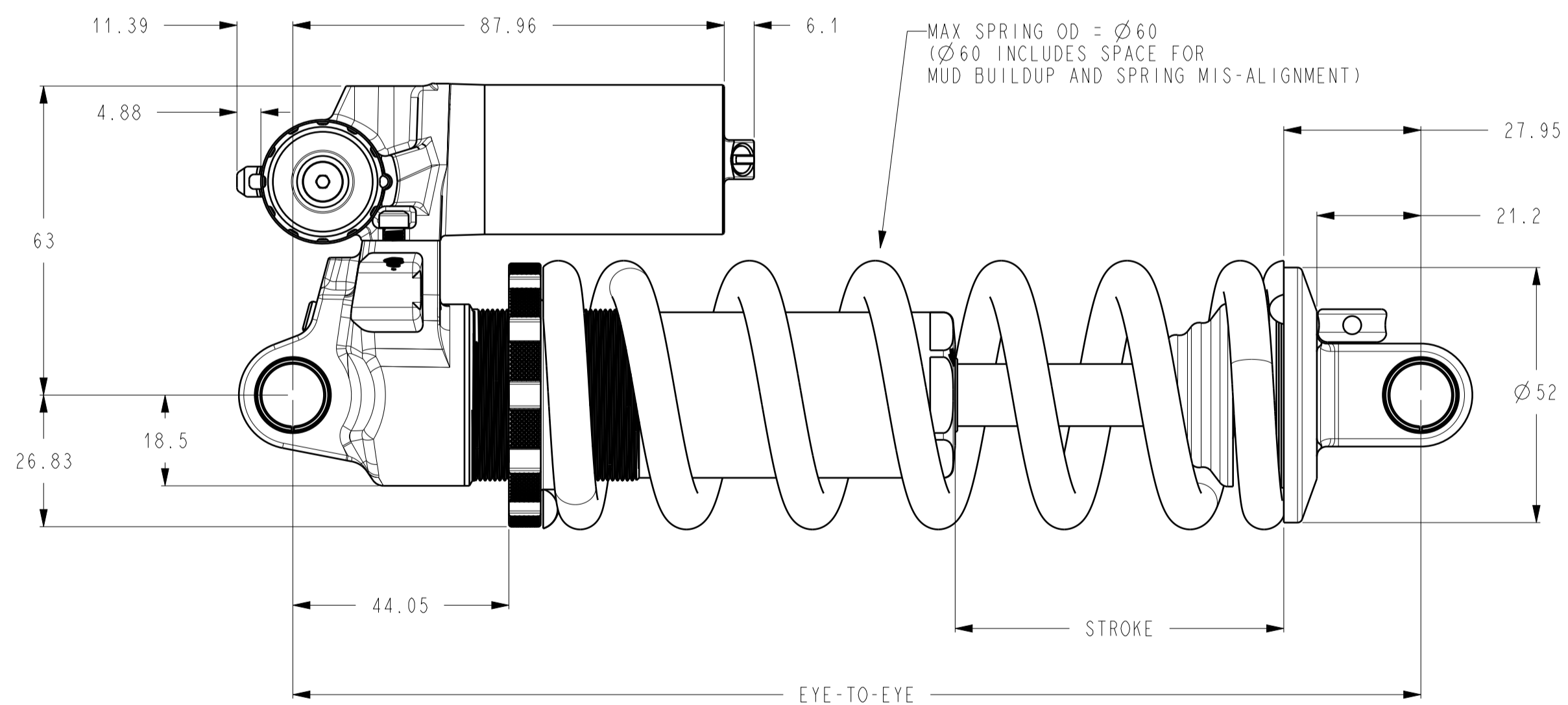
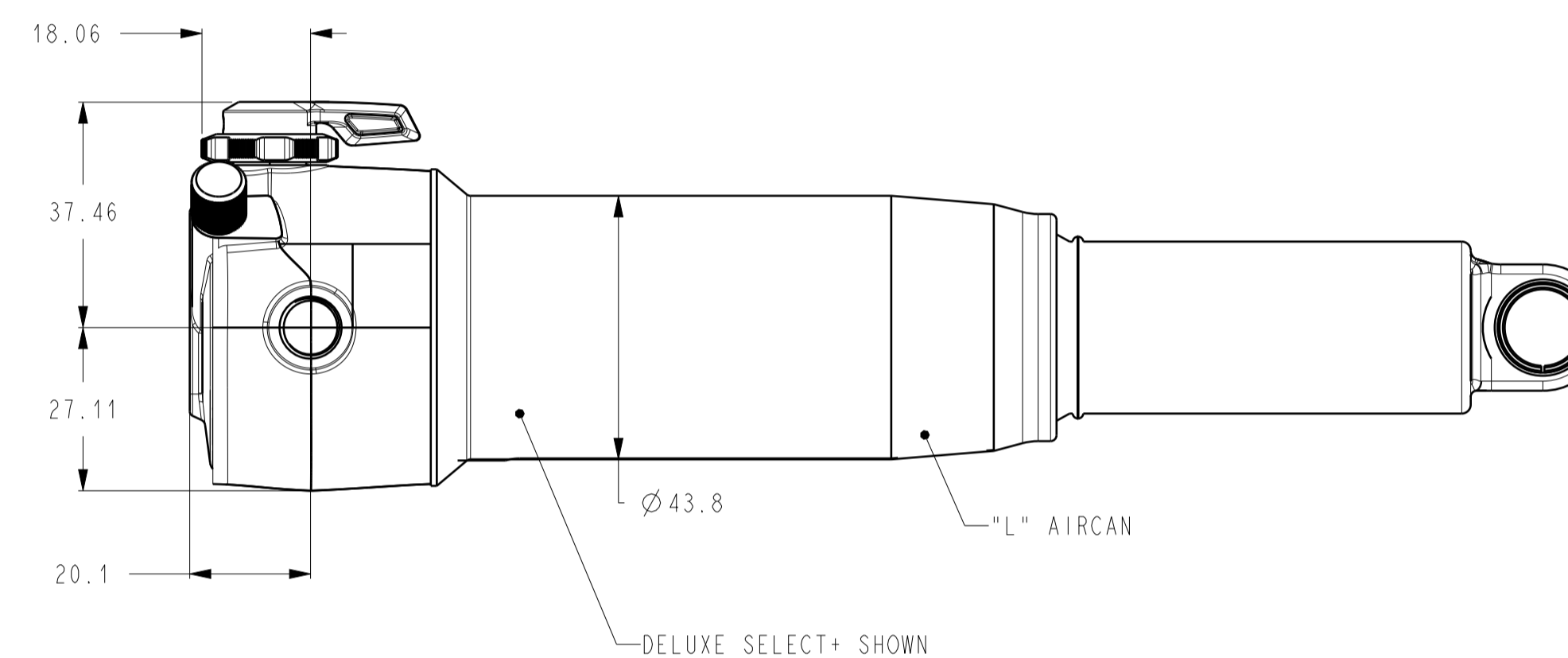
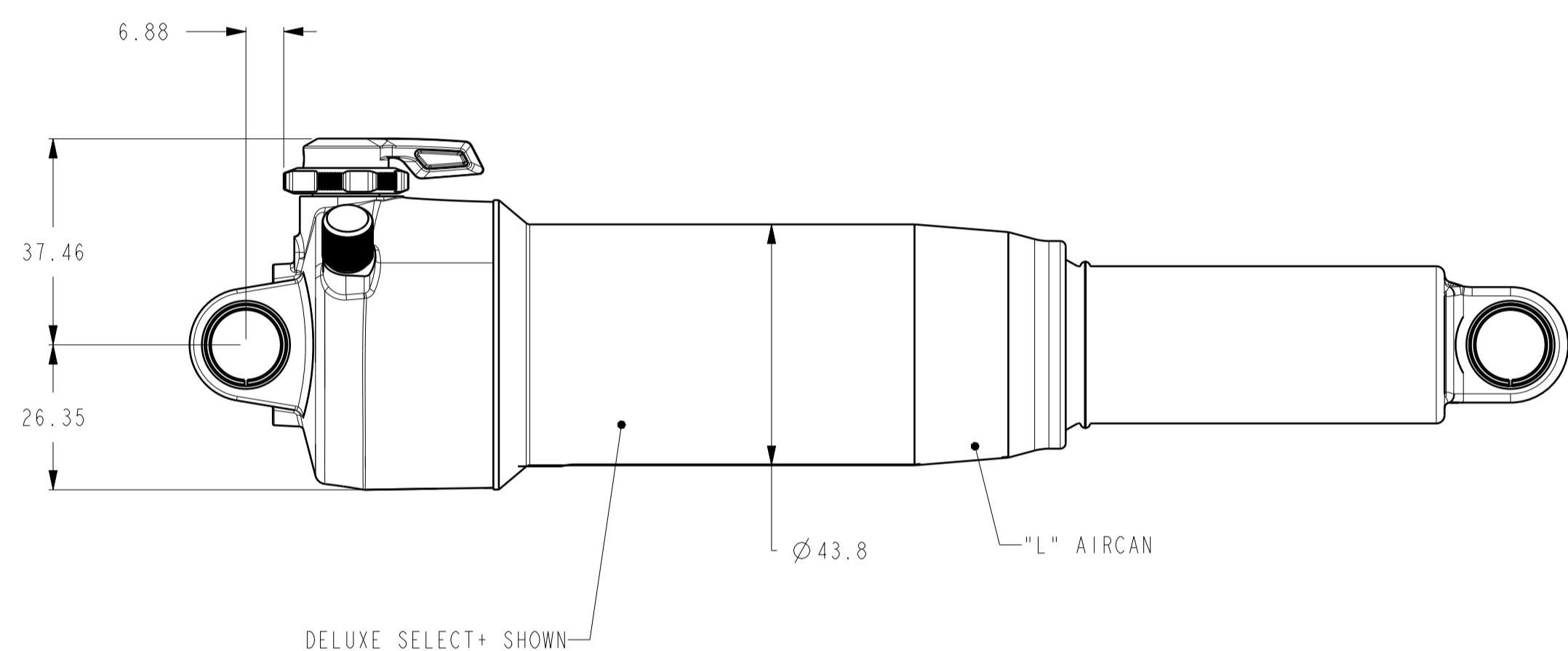
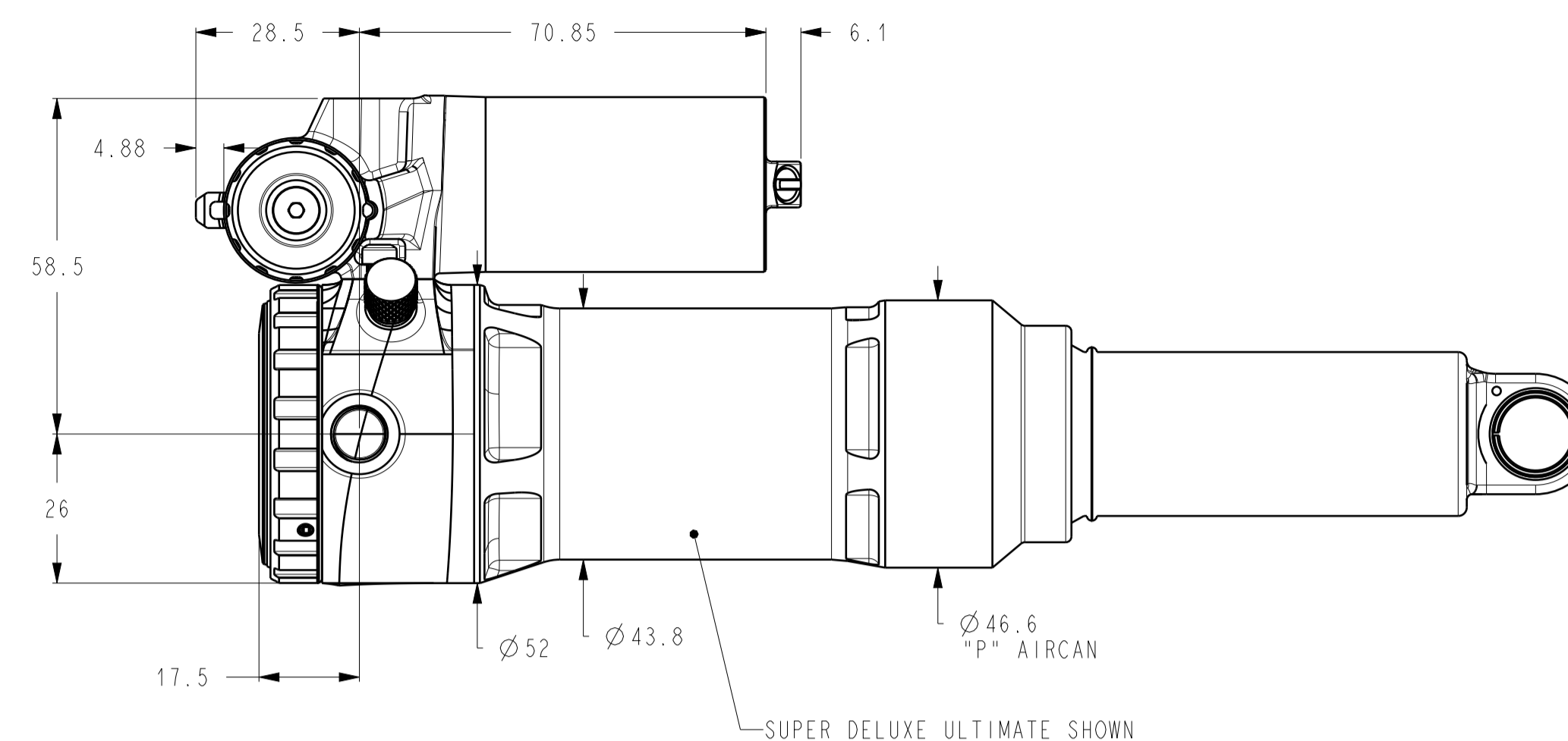
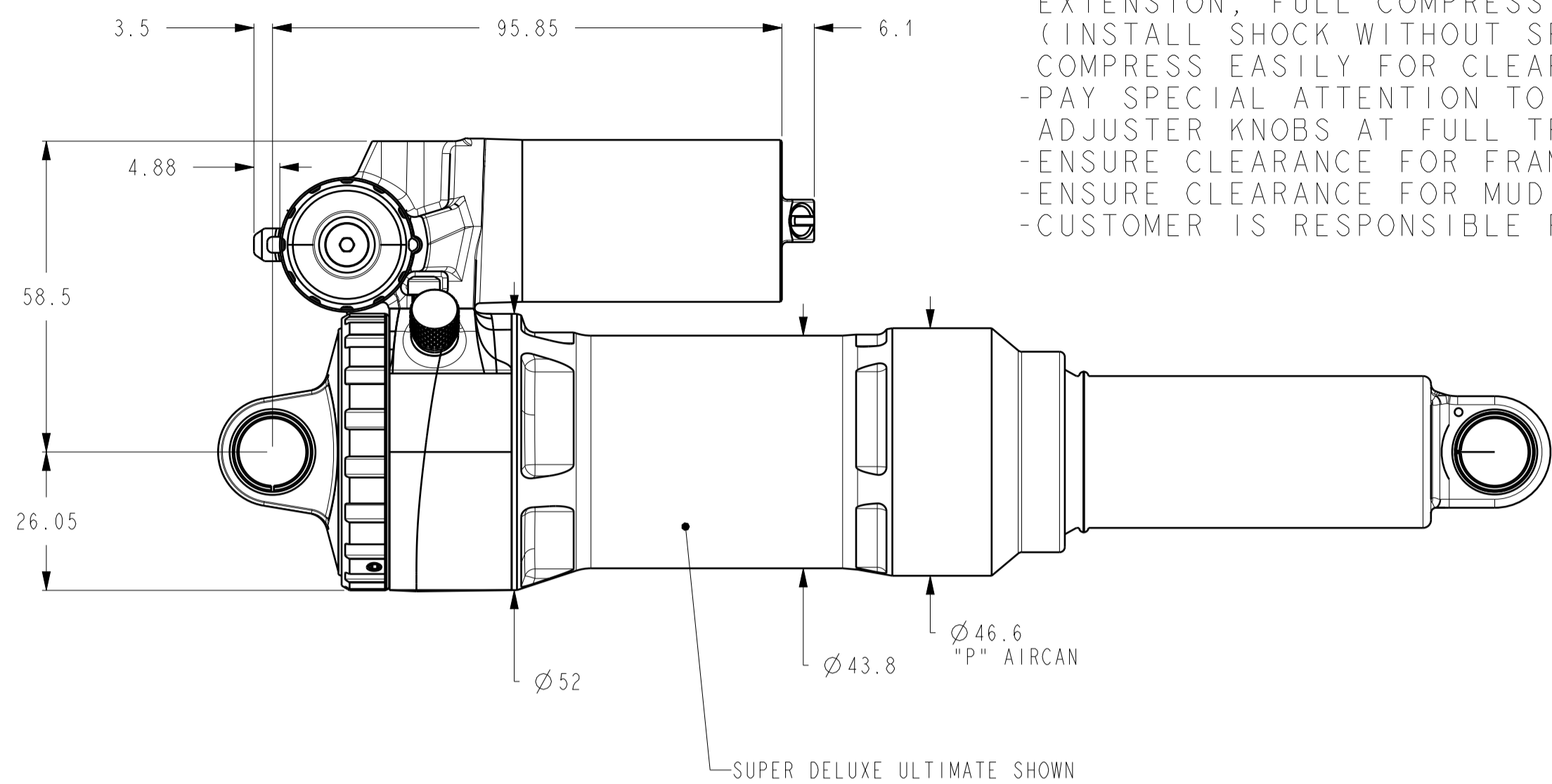

EYE-TO-EYE (STANDARD, BEARING)	STROKE OPTIONS
250	75, 72.5, 70, 67.5
230	65, 62.5, 60, 57.5
210	55, 52.5, 50, 47.5
190	45, 42.5, 40, 37.5

EYE-TO-EYE (TRUNNION)	STROKE OPTIONS
225	75, 72.5, 70, 67.5
205	65, 62.5, 60, 57.5
185	55, 52.5, 50, 47.5
165	45, 42.5, 40, 37.5